



[www.FGWilson.com](http://www.FGWilson.com)

# CAE/CAL Modular Acoustic Enclosures

## P7.5-2S – P22-4 Range

The FG Wilson fully weatherproof sound attenuated CAE/CAL enclosures reduce sound levels to comply with the stage 2 levels of the European Community Directive 2000/14/EC which became effective 3 January 2006.

These enclosures incorporate internally mounted exhaust silencers and are of extremely rugged construction in order to withstand the rough handling common on many construction sites.



They provide the benefit of increased ease of installation and serviceability, all within a compact footprint.



**FG Wilson has manufacturing facilities in the following locations:**

Northern Ireland • Brazil • China • India • USA

With headquarters in Northern Ireland, FG Wilson operates through a Global Dealer Network.

To contact your local Sales Office please visit the FG Wilson website at [www.FGWilson.com](http://www.FGWilson.com)

# CAE Enclosures



## Highly Corrosion Resistant Construction

- Stainless steel locks
- Black zinc die cast hinges on gullwing doors tested and proven to withstand extremely corrosive conditions
- Zinc plated or stainless steel fasteners and hinges
- Body made from steel components pre-treated with zinc phosphate prior to polyester powder coating

## Excellent Access for Maintenance

- Top hung gullwing doors
- Hinged and lockable end panels
- Radiator fill access through radiator end panel
- Lube oil drain piped to exterior of the canopy

## Transportability

- Tested and certified single point lifting facility

## Security and Safety

- Perspex control panel viewing window in a lockable access door
- Emergency stop button mounted on canopy exterior
- End panels secured by internal latches with safety retainer
- Cooling fan and battery charging alternator fully guarded
- Fuel fill and battery can only be reached via lockable access doors
- Exhaust silencing system enclosed for operator safety

## Optional Features

- Lockable vandal proof control panel cover in place of window

## Sound Pressure Levels (dBA) - CAE

		50 Hz at 1500 RPM						60 Hz at 1800 RPM						
		15m (50ft)		7m (23ft)		1m (3ft)		15m (50ft)		7m (23ft)		1m (3ft)		
Generating Set Model	LWA	75% Load	100% Load	75% Load	100% Load	75% Load	100% Load	75% Load	100% Load	75% Load	100% Load	75% Load	100% Load	
<b>3 Phase Models</b>														
P9.5-2*	Prime	-	58.5	59.5	64.5	65.5	72.9	74.1	61.3	62.3	67.3	68.3	76.2	77.2
	Standby	-	58.7	59.8	64.7	65.8	73.1	74.5	61.6	62.8	67.6	68.8	76.5	77.7
P13.5-4	Prime	90	59.7	61.0	65.7	67.0	75.4	76.7	61.3	63.2	67.3	69.2	77.2	79.4
	Standby	90	60.1	61.5	66.1	67.5	75.8	77.2	61.7	64.0	67.7	70.0	77.7	80.2
P18-4	Prime	91	58.6	60.1	64.6	66.1	73.5	74.9	60.7	61.6	66.7	67.6	75.5	76.4
	Standby	91	59.0	60.7	65.0	66.7	73.8	75.5	60.9	62.1	66.9	68.1	75.7	76.8
P22-4	Prime	91	59.5	61.6	65.5	67.6	74.3	76.4	61.1	62.5	67.1	68.5	75.9	77.2
	Standby	91	60.1	62.6	66.1	68.6	74.9	77.5	61.5	63.3	67.5	69.3	76.2	78.0
<b>Single Phase Models</b>														
P7.5-2S*	Prime	-	58.5	59.5	64.5	65.5	72.9	74.1	61.3	62.3	67.3	67.9	75.0	76.1
	Standby	-	58.7	59.8	64.7	65.8	73.1	74.5	61.6	62.8	67.6	68.8	76.5	77.7
P11-4S	Prime	90	59.7	61.0	65.7	67.0	75.4	76.7	61.3	63.2	67.3	69.2	77.2	79.4
	Standby	90	60.1	61.5	66.1	67.5	75.8	77.2	61.7	64.0	67.7	70.0	77.7	80.2
P14-4S	Prime	91	58.6	60.0	64.6	66.0	73.4	74.8	60.7	61.6	66.7	67.6	75.5	76.4
	Standby	91	58.9	60.5	64.9	66.5	73.7	75.3	60.9	62.1	66.9	68.1	75.7	76.8
P16.5-4S	Prime	91	59.2	61.0	65.2	67.0	74.0	75.8	61.1	62.5	67.1	68.5	75.9	77.2
	Standby	91	59.7	61.9	65.7	67.9	74.5	76.8	61.5	63.3	67.5	69.3	76.2	78.0

Levels in accordance with European Noise Directive (2000/14/EC).

\*LWA figures not recorded as models are not available in the EU.

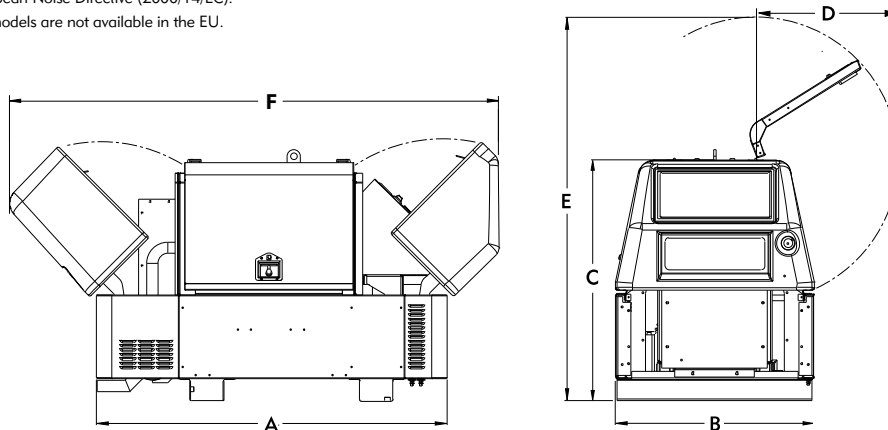

## Dimensions and Weights - CAE

Generating Set Model	A: mm (in)	B: mm (in)	C: mm (in)	D: mm (in)	E: mm (in)	F: mm (in)	Weight: kg (lb)	Fuel Capacity: l (US gal)
<b>3 Phase Models</b>								
P9.5-2	1593 (62.7)	900 (35.4)	1275 (50.2)	840 (33.1)	1878 (73.9)	2228 (87.7)	494 (1089)	45 (12)
P13.5-4	1593 (62.7)	900 (35.4)	1275 (50.2)	840 (33.1)	1878 (73.9)	2228 (87.7)	580 (1279)	45 (12)
P18-4	1593 (62.7)	900 (35.4)	1275 (50.2)	840 (33.1)	1878 (73.9)	2228 (87.7)	641 (1413)	45 (12)
P22-4	1593 (62.7)	900 (35.4)	1275 (50.2)	840 (33.1)	1878 (73.9)	2228 (87.7)	654 (1442)	45 (12)
<b>Single Phase Models</b>								
P7.5-2S	1593 (62.7)	900 (35.4)	1275 (50.2)	840 (33.1)	1878 (73.9)	2228 (87.7)	494 (1089)	45 (12)
P11-4S	1593 (62.7)	900 (35.4)	1275 (50.2)	840 (33.1)	1878 (73.9)	2228 (87.7)	580 (1279)	45 (12)
P14-4S	1593 (62.7)	900 (35.4)	1275 (50.2)	840 (33.1)	1878 (73.9)	2228 (87.7)	641 (1413)	45 (12)
P16.5-4S	1593 (62.7)	900 (35.4)	1275 (50.2)	840 (33.1)	1878 (73.9)	2228 (87.7)	654 (1442)	45 (12)

Note: Net Weight with lube oil, no coolant, no fuel; Clearance required on all four sides.

# CAL Enclosures



## Highly Corrosion Resistant Construction

- Black zinc die cast hinges tested and proven to withstand extremely corrosive conditions
- Zinc passivated and stainless steel fasteners
- Body made from sheet steel components with polyester powder coating at 200°C (392°F)

## Excellent Access for Maintenance

- Vertically hinged side doors allowing 180° opening rotation
- Front and rear “lift-off” access panels
- Radiator fill access through cover in canopy roof
- Lube oil drain and radiator drain

## Security and Safety

- Perspex control panel viewing window in a lockable access door
- Emergency stop button mounted on canopy exterior
- Cooling fan and battery charging alternator fully guarded
- Fuel fill and battery can only be reached via lockable access doors
- Exhaust silencing system enclosed for operator safety

## Transportability

- Lifting points on baseframe

## Sound Pressure Levels (dBA) - CAL

		50 Hz @ 1500 RPM						60 Hz @ 1800 RPM						
		LWA	15m (50ft)		7m (23ft)		1m (3ft)		15m (50ft)		7m (23ft)		1m (3ft)	
Generating Set Model			75% Load	100% Load	75% Load	100% Load	75% Load	100% Load	75% Load	100% Load	75% Load	100% Load	75% Load	100% Load
<b>3 Phase Models</b>														
P13.5-4	Prime	86	52,7	53,9	58,7	59,9	70,8	71,9	55,0	56,0	61,0	62,0	72,3	74,0
	Standby	86	53,1	54,5	59,1	60,5	71,1	72,4	55,3	56,4	61,3	62,4	72,7	74,6
P18-4	Prime	91	55,6	56,0	61,6	62,0	72,8	73,4	58,4	59,7	64,4	65,7	75,3	77,2
	Standby	91	55,7	56,2	61,7	62,2	72,9	73,7	58,7	60,4	64,7	66,4	75,8	78,1
P22-4	Prime	91	55,8	56,4	61,8	62,4	73,2	74,2	59,0	60,9	65,0	66,9	76,1	78,7
	Standby	91	56,0	56,7	62,0	62,7	73,4	74,7	59,5	62,0	65,5	68,0	76,9	80,1
<b>Single Phase Models</b>														
P11-4S	Prime	86	52,7	53,9	58,7	59,9	70,8	71,9	55,0	56,0	61,0	62,0	72,3	74,0
	Standby	86	53,1	54,5	59,1	60,5	71,1	72,4	55,3	56,4	61,3	62,4	72,7	74,6
P14-4S	Prime	91	55,6	56,0	61,6	62,0	72,7	73,4	55,0	56,0	61,0	62,0	72,3	74,0
	Standby	91	55,7	56,1	61,7	62,1	72,9	73,6	55,3	56,4	61,3	62,4	72,7	74,6
P16.5-4S	Prime	91	55,8	56,2	61,8	62,2	73,0	73,9	59,0	60,9	65,0	66,9	76,1	78,7
	Standby	91	55,9	56,5	61,9	62,5	73,3	74,3	59,5	62,0	65,5	68,0	76,9	80,1

Levels in accordance with European Noise Directive (2000/14/EC)

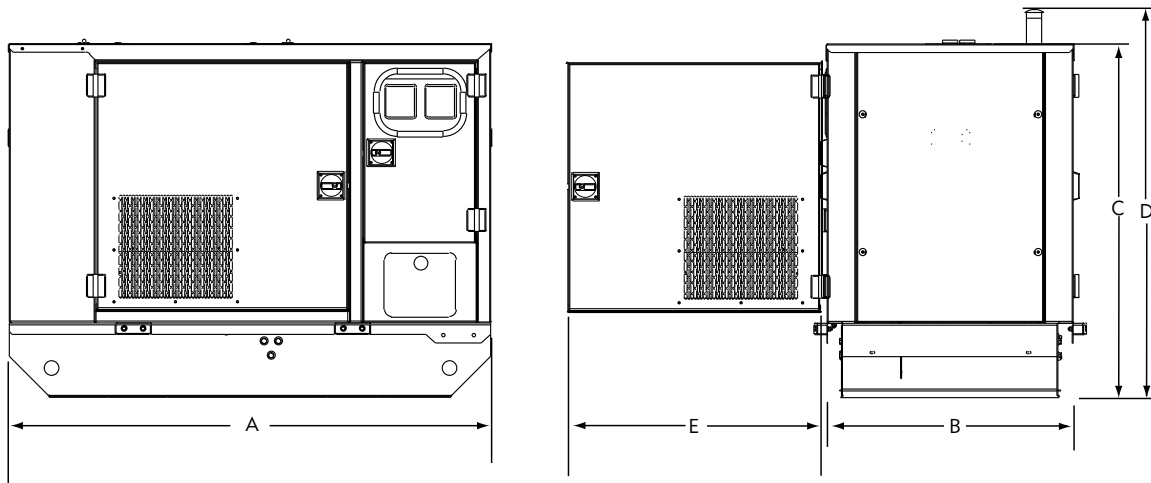

## Dimensions and Weights - CAL

Generating Set Model	A: mm (in)	B: mm (in)	C: mm (in)	D: mm (in)	E: mm (in)	Weight: kg (lb)	Fuel Capacity: l (US gal)
<b>3 Phase Models</b>							
P13.5-4	1684 (66,3)	860 (33,9)	1253 (49,3)	1385 (54,5)	880 (34,6)†	645 (1422)	45,0 (12,0)
P18-4	1684 (66,3)	860 (33,9)	1253 (49,3)	1385 (54,5)	880 (34,6)†	706 (1556)	45,0 (12,0)
P22-4	1684 (66,3)	860 (33,9)	1253 (49,3)	1385 (54,5)	880 (34,6)†	719 (1585)	45,0 (12,0)
<b>Single Phase Models</b>							
P11-4S	1684 (66,3)	860 (33,9)	1253 (49,3)	1385 (54,5)	880 (34,6)†	645 (1422)	45,0 (12,0)
P14-4S	1684 (66,3)	860 (33,9)	1253 (49,3)	1385 (54,5)	880 (34,6)†	706 (1556)	45,0 (12,0)
P16.5-4S	1684 (66,3)	860 (33,9)	1253 (49,3)	1385 (54,5)	880 (34,6)†	719 (1585)	45,0 (12,0)

Note: Net Weight with lube oil, no fuel. †Clearance required both sides.

**FG Wilson has manufacturing facilities in the following locations:**

Northern Ireland • Brazil • China • India • USA

With headquarters in Northern Ireland, FG Wilson operates through a Global Dealer Network.

To contact your local Sales Office please visit the FG Wilson website at [www.FGWilson.com](http://www.FGWilson.com)

In line with our policy of continuous product development, we reserve the right to change specification without notice.

11-22kVACAE&CALEnclosures/1110/GB